

Power Operational Amplifiers

FEATURES

- ◆ Low Cost
- ◆ Wide Common Mode Range
- ◆ Standard Supply Voltage
 - ◆ Single Supply: 10V to 50V
- ◆ Output Current - 150mA Continuous
- ◆ Output Voltage 50-350V
- ◆ 350 V/ μ S Slew Rate
- ◆ 200 kHz Power Bandwidth

Applications

- ◆ Piezoelectric positioning and Actuation
- ◆ Electrostatic Deflection
- ◆ Deformable Mirror Actuators
- ◆ Chemical and Biological Stimulators

GENERAL DESCRIPTION

The MP400FC combines a high voltage, high speed precision power op amp with a supply voltage boost function in an integrated thermally conductive module. The voltage boost function uses a switch mode power supply (SMPS) to boost the input power supply voltage. This allows the user the benefits of using his standard 12V or 24V buss without the need to design a high voltage supply to power the op amp. The SMPS voltage is adjustable from 50-350V, allowing for op amp output voltages up to 340V. External phase compensation provides the user with the flexibility to tailor gain, slew rate and bandwidth for a specific application. The unique design of this amplifier provides extremely high slew rates in pulse applications while maintaining low quiescent current. The output stage is well protected with a user defined current limit. Safe Operating Area (SOA) must be observed for reliable operation.

EQUIVALENT CIRCUIT DIAGRAM

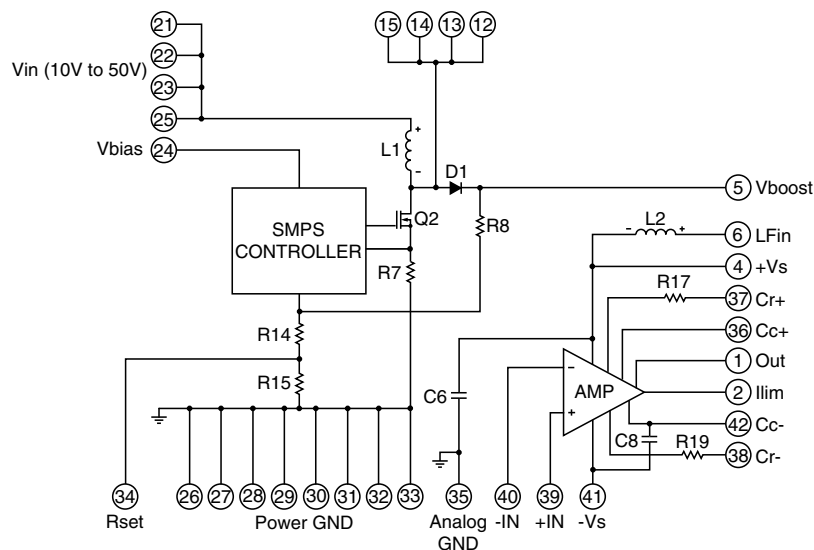

1. CHARACTERISTICS AND SPECIFICATIONS

NOTES:

1. (All Min/Max characteristics and specifications are guaranteed over the Specified Operating Conditions. Typical performance characteristics and specifications are derived from measurements taken at typical supply voltages and $T_c = 25^\circ\text{C}$).

ABSOLUTE MAXIMUM RATINGS

Parameter	Symbol	Min	Max	Units
SUPPLY VOLTAGE, +Vcc to GND			50	V
OUTPUT CURRENT, peak within SOA			200	mA
POWER DISSIPATION, internal, DC, Amplifier			14.2	W
OUTPUT POWER, SMPS			67	W
INPUT VOLTAGE, Differential		-16	16	V
INPUT VOLTAGE, Common Mode		-16	16	V
TEMPERATURE, pin solder, 10s			225	$^\circ\text{C}$
TEMPERATURE, junction (Note 2)			150	$^\circ\text{C}$
TEMPERATURE RANGE, storage		-40	105	$^\circ\text{C}$
OPERATING TEMPERATURE, case		-40	85	$^\circ\text{C}$

2. Long term operation at the maximum junction temperature will result in reduced product life. Derate power dissipation to achieve high MTTF.

SPECIFICATIONS

Parameter	Test Conditions	Min	Typ	Max	Units
AMPLIFIER INPUT					
OFFSET VOLTAGE			8	40	mV
OFFSET VOLTAGE vs. temperature	0 to 85 $^\circ\text{C}$ (Case)		-63		$\mu\text{V}/^\circ\text{C}$
OFFSET VOLTAGE vs. supply				32	$\mu\text{V}/\text{V}$
BIAS CURRENT, initial (Note 3)			8.5	200	pA
OFFSET CURRENT, initial			12	400	pA
INPUT RESISTANCE, DC			10^6		Ω
COMMON MODE VOLTAGE RANGE, pos.			+Vs - 2		V
COMMON MODE VOLTAGE RANGE, neg.			-Vs + 5.5		V
COMMON MODE REJECTION, DC		90	118		dB
NOISE	700KHz bandwidth		418mV		$\mu\text{V RMS}$
AMPLIFIER GAIN					
OPEN LOOP @ 15Hz		89	120		dB
GAIN BANDWIDTH PRODUCT @ 1MHz			1		MHz
PHASE MARGIN	Full temperature range		50		$^\circ$
AMPLIFIER OUTPUT					
VOLTAGE SWING	$I_o = 10\text{mA}$		$ V_s - 2$		V
VOLTAGE SWING	$I_o = 100\text{mA}$		$ V_s - 8.6$	$ V_s - 12$	V
VOLTAGE SWING	$I_o = 150\text{mA}$		$ V_s - 10$		V
CURRENT, continuous, DC		150			mA
SLEW RATE		100	350		V/ μS

Parameter	Test Conditions	Min	Typ	Max	Units
SETTLING TIME, to 0.1%	2V Step		1		μS
RESISTANCE, No load	$R_{LIM} = 6.2\Omega$		44		Ω
POWER BANDWIDTH, 300V _{P-P}	$+V_S = 160V, -V_S = -160V$		200		kHz
CURRENT, quiescent, amplifier only		0.2	0.7	2.5	mA
SMPS					
INPUT VOLTAGE, V_{IN}		10		50	V
SMPS OUTPUT VOLTAGE, V_B		46.75		365	V
SMPS OUTPUT CURRENT, I_S	$V_B = 10 \times V_{IN}$	150			mA
OUTPUT VOLTAGE TOLERANCE	$V_B \leq 10 \times V_{IN}, I_S \leq 150mA,$ $R_{SET} = 1\%$		+/-2	6.5	%
VOLTAGE BOOST			10		x input V
THERMAL					
RESISTANCE, DC, junction to case	Full temperature range, f<60Hz		7.7	8.8	°C/W
RESISTANCE, junction to air	Full temperature range		46		°C/W
TEMPERATURE RANGE, case		0		70	°C

3. Doubles for every 10°C of temperature increase.
4. $+V_S$ and $-V_S$ denote the positive and negative supply voltages to the output stage.

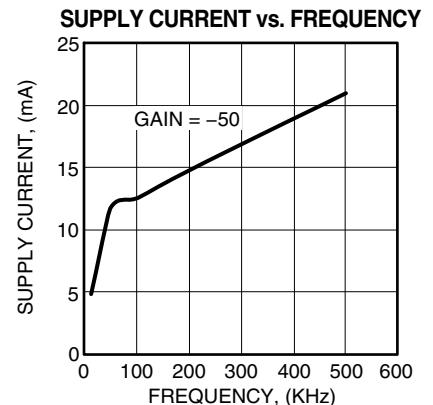
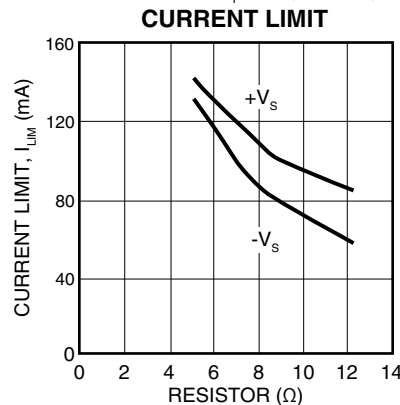
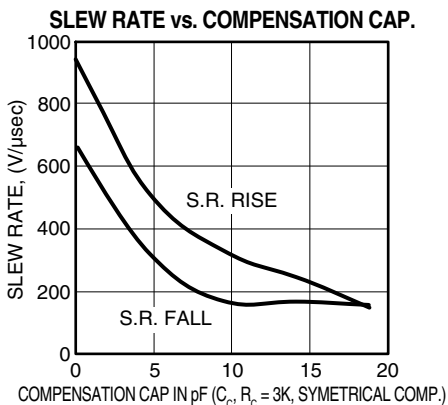
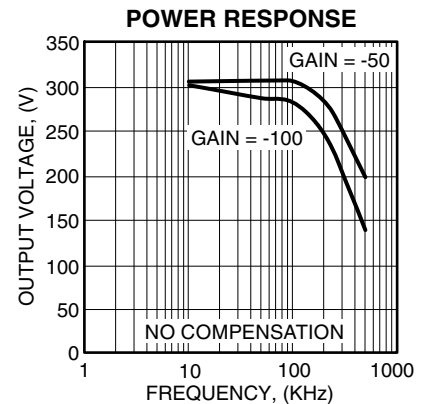
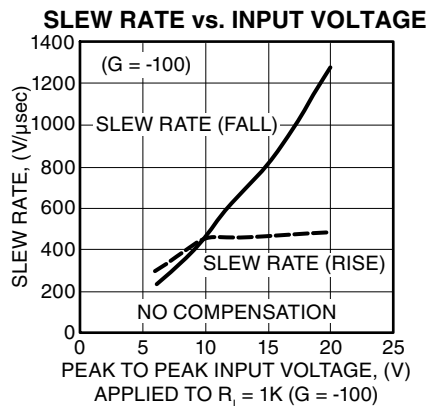
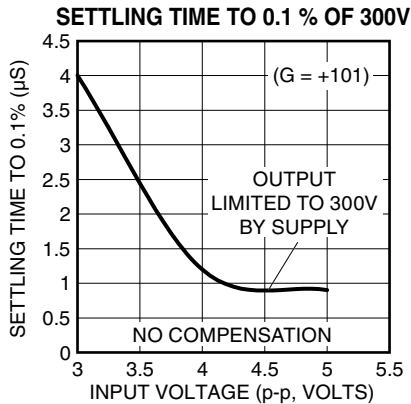

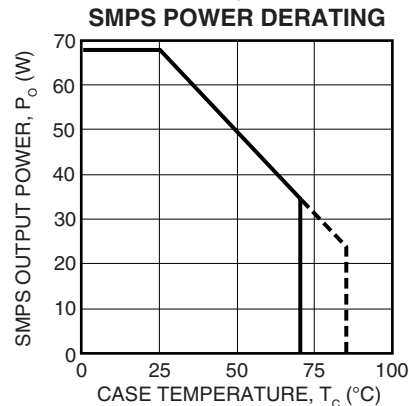
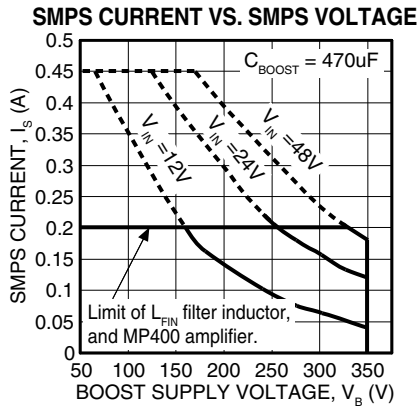
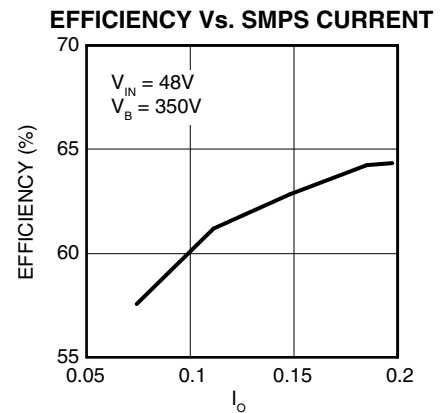
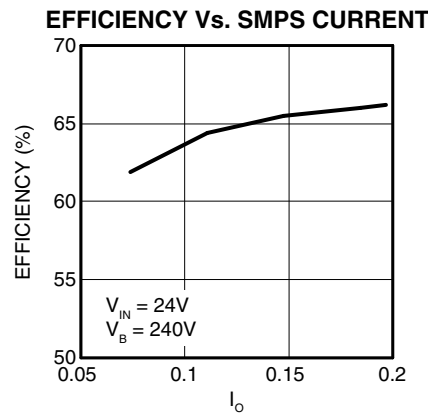
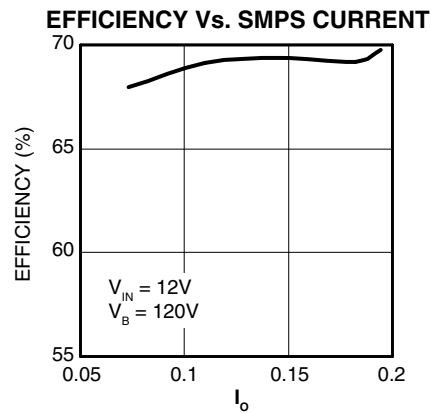
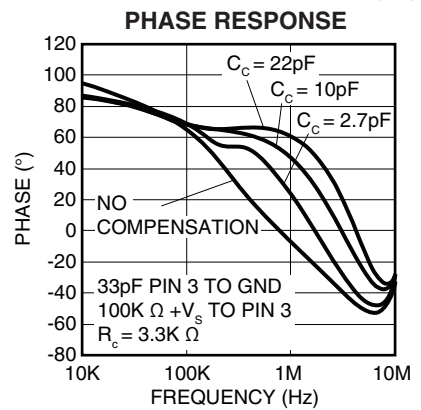
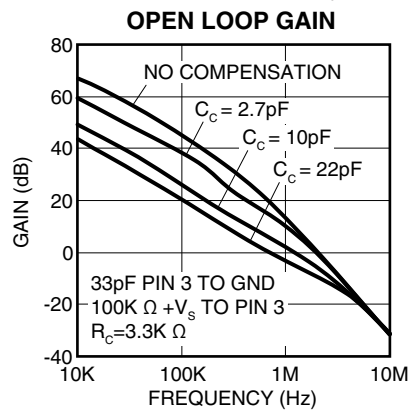
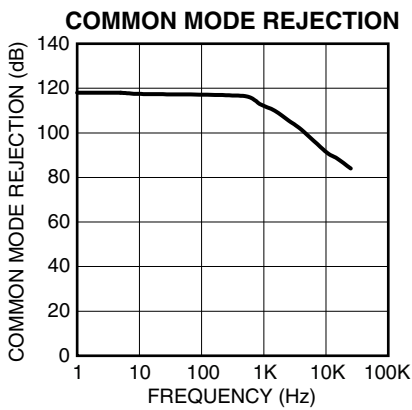
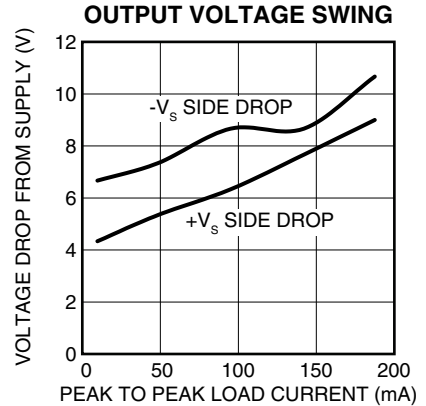
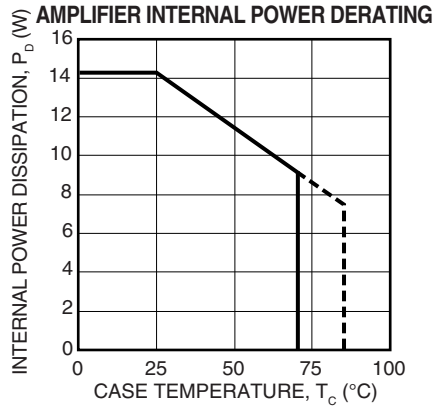
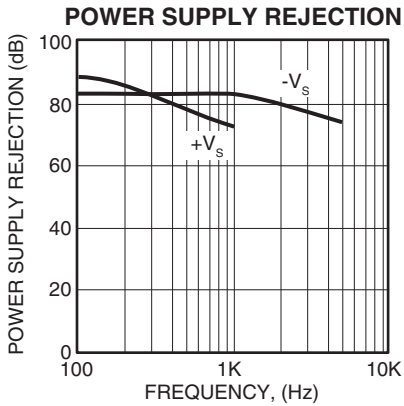

EXTERNAL CONNECTIONS

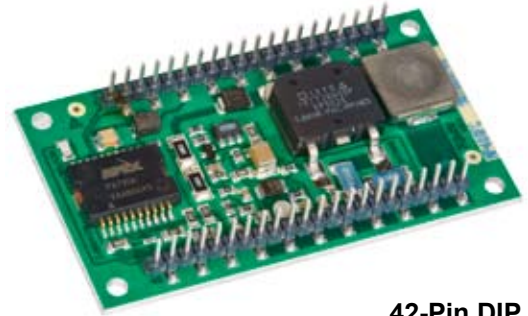
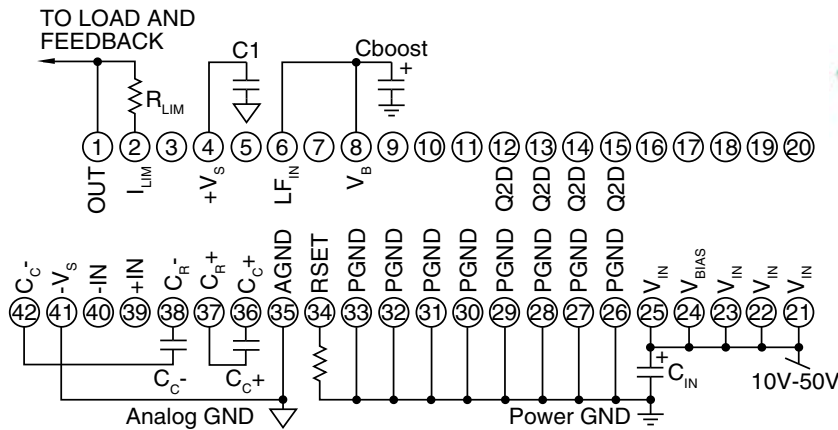

**42-Pin DIP
Package Style FC**

PIN DESCRIPTIONS

Pin #	Pin name	Description
21 - 23, 25	V _{IN}	Input voltage pins for the on board high voltage switch mode power supply.
24	V _{BIAS}	Input voltage pin for the boost controller circuitry. This pin is typically tied to V _{IN} .
12 - 15	Q2D	Drain node of the SMPS MOSFET switch. An external RC snubber may be connect from this node to power ground to reduce or eliminate overshoot and ringing at switch turn off, reducing switching noise on the SMPS.
8	V _B	This is the output of the high voltage SMPS and typically is tied to pin 6, L _{FIN} . Other loads can be added to this pin as long as the maximum output power of the SMPS is not exceeded. For proper operation, an external high voltage, low ESR capacitor must be connected to this pin. Refer to the paragraph titled "SMPS Output Capacitor".
6	L _{FIN}	The high voltage SMPS, V _B , is connected to this pin to power the MP400FC amplifier through a 47uH filter inductor. The supply current in to this pin can not exceed 200mA.
4	+V _S	MP400FC amplifier high voltage supply pin. This pin is used for external supply bypass. A high quality ceramic capacitor of at least 1uF should be used. The high voltage SMPS, V _B , can be connected directly to this pin, bypassing the 47uH filter inductor.
34	RSET	SMPS voltage set resistor. A resistor is connected from this pin to power ground to set the SMPS voltage.
26 - 33	PGND	Power ground. SMPS switching circuits are referenced to ground through these pins.
35	AGND	Analog ground for MP400FC amplifier circuits. AGND and PGND are connected at one point on the MP400FC. Avoid external connects between AGND and PGND.
41	-Vs	This pin is typically connected to AGND. However, an external negative supply voltage can be connected to this pin.
39	+IN	Amplifier non-inverting input
40	-IN	Amplifier inverting input
1	V _{OUT}	Amplifier output
2	I _{LIM}	Amplifier current limit. A current limit resistor must be connected between I _{LIM} and V _{OUT} . $R_{LIM} = 0.7/I_{LIM}$
36	CR+	+ side compensation capacitor connection one.
37	CC+	+ side compensation capacitor connection two.
38	CR-	- side compensation capacitor connection one.
42	CC-	- side compensation capacitor connection two.

TYPICAL APPLICATION

The MP400FC is ideally suited to driving both piezo actuation and deflection applications off of a single low voltage supply. The circuit above boosts a system 24V buss to 350V to drive an ink jet print head. The MP400FCs high speed deflection amplifier is biased for single supply operation by external resistors R2 – R6, so that a 0 to 5V DAC can be used as the input to the amplifier to drive the print head from 0 to >300V.

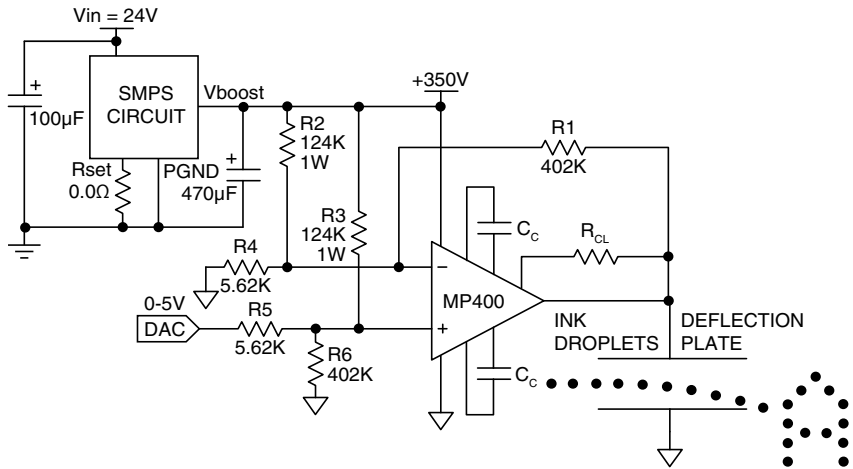

GENERAL

Please read Application Note 1 “General Operating Considerations” which covers stability, power supplies, heat sinking, mounting, current limit, SOA interpretation, and specification interpretation. Visit www.apexmicrotech.com for design tools that help automate tasks such as calculations for stability, internal power dissipation, current limit, heat sink selection, Apex’s complete Application Notes library, Technical Seminar Workbook and Evaluation Kits.

CURRENT LIMIT

For proper operation, the current limit resistor, Rlim, must be connected as shown in the external connections diagram. The minimum value is 3.5Ω, however for maximum reliability and protection, the resistor should be set as high as possible. The value of the resistor is calculated as follows, with Ilim in A; the maximum practical value is 30Ω.

$$R_{lim} = 0.7 / I_{lim}$$

SAFE OPERATING AREA

The MOSFET output stage of the MP400FC amplifier is not limited by second breakdown considerations as in bipolar output stages. Only thermal considerations and current handling capabilities limit the SOA. The output stage is protected against transient flyback by the parasitic body diodes of the output stage MOSFET structure. However, for protection against sustained high energy flyback external fast-recovery diodes must be used..

SUPPLY CURRENT

The MP400FC features a class A/B driver stage to drive the output MOSFETs and an innovative input stage to achieve very high slew rates. The supply current drawn by the MP400FC, even with no load, varies with the slew rate of the output signal as shown in the graph below.

STABILITY

The MP400FC is externally compensated and performance can be tailored to the application. Use the graphs of small signal response and power response as a guide. The compensation capacitor Cc must be rated at 500V working voltage. NPO capacitors are recommended. The compensation capacitors must be mounted closely to the amplifier pins 36 & 37 and 38 & 42 to avoid spurious oscillation.

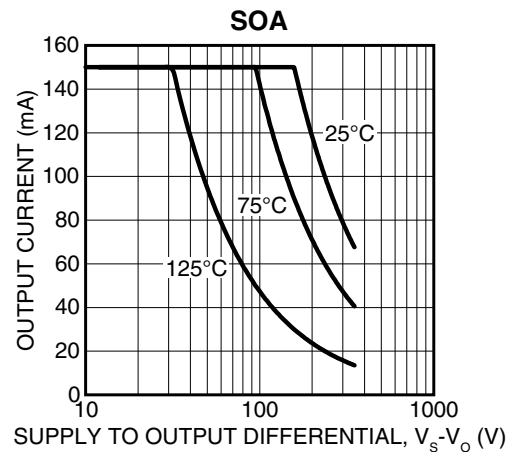

SUPPLY CURRENT vs. FREQUENCY

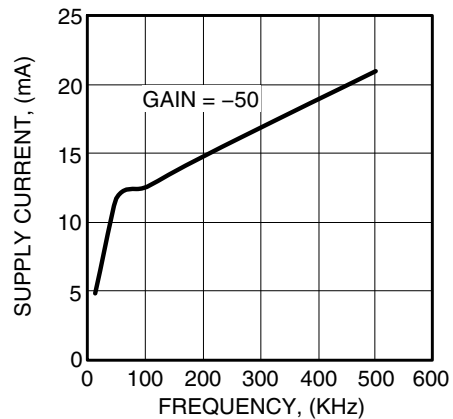

SMPS OPERATION

The MP400FC is designed to operate off of a standard voltage rail. Typical values include 12V, 24V, or 48V. The addition of the on-board SMPS eliminates the need to design or purchase a high voltage power supply. The only inputs required by the SMPS are the V_{IN} source. Input and output filter capacitor, and boost voltage set resistor (RSET).

The SMPS output can be adjusted between a minimum of 50V to a maximum of 350V. The voltage boost adjustment is independent of V_{IN} . Adjustment to the boost level is made through a resistor from the RSET pin to ground. The resistor value is:

$$R_{set} = (3.16E6 \cdot (351 - V_{boost})) / (V_{boost} - 1.25) / (4.42E3 - (715 \cdot (351 - V_{boost})) / (V_{boost} - 1.25))$$

Where V_{boost} = desired SMPS voltage.

Example: 1) Desired V_{boost} = 160V
2) R_{set} = 1K (1074 by equation)

If RSET is open, V_{boost} will be 50V. If RSET is shorted to ground V_{boost} will be limited to 350V.

SMPS OUTPUT CAPACITOR

An external SMPS output filter capacitor is required for proper operation. ESR considerations prevail in the choice of the output filter capacitor. Select the highest value capacitor that meets the following ESR requirement. The minimum value for C_{BOOST} is 100uF.

$$ESR = dV_o / I_{LPK}$$

Where,

dV_o = the maximum acceptable output ripple voltage

I_{LPK} = Peak inductor current = $(1/L) \cdot V_{in} \cdot t_{on}$

L = 10E-6 if the internal inductor is used.

V_{in} = Input voltage of the application.

t_{on} = $\sqrt{2 \cdot I_o \cdot L \cdot ((V_o + 0.6 - V_{in}) / (F_{sw} \cdot V_{in}^2))}$

V_{boost} = The boost supply voltage of the application.

I_o = The maximum continuous output current for the application.

F_{sw} = 100KHz switching frequency of the MP400FC boost supply.

SMPS INPUT CAPACITOR

An external input capacitor is required. This capacitor should be at least 100uF.

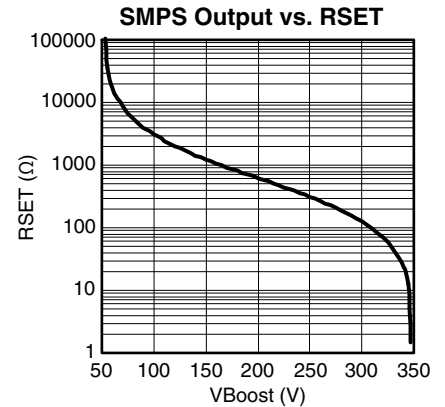

THERMAL CONSIDERATIONS

For reliable operation the MP400FC will require a heatsink for most applications. When choosing the heatsink the power dissipation in the op amp and the SMPS MOSFET switch (Q2) are both considered. The power dissipation of the op amp is determined in the same manner as any power op amp. The power dissipation of the MOSFET switch (Q2) is the sum of the power dissipation due to conduction and the switching power.

$$P_{D(Q2)} = (I_{IN(pk)}^2 \cdot R_{DS(ON)} \cdot D) + (I_{IN(pk)} \cdot V_{IN} \cdot t_r \cdot F_{SW})$$

Where:

V_{IN} = SMPS input voltage

V_B = SMPS output voltage

I_O = total SMPS output current

F_{SW} = 100KHz

$R_{DS(ON)}$ = 0.621Ω

t_r = 82 x 10⁻⁹s

D = $T_1 \cdot F_{SW}$

$$t_1 = \sqrt{2 \cdot I_O \cdot 10 \times 10^{-6} \cdot \left(\frac{V_B - V_{IN}}{F_{SW} \cdot V_{IN}^2} \right)}$$

$$I_{IN(pk)} = \frac{V_B \cdot t_d}{10 \times 10^{-6}}$$

$$t_d = t_1 \cdot \left(\frac{V_B}{V_B - V_{IN}} \right) - t_1$$

CONTACTING CIRRUS LOGIC SUPPORT

For all Apex Precision Power product questions and inquiries call toll free 800-546-2739 in North America. For International customer support, contact a local Cirrus Logic Sales Representative.

To find the one nearest to you, go to <http://www.cirrus.com>

IMPORTANT NOTICE

Cirrus Logic, Inc. and its subsidiaries ("Cirrus") believe that the information contained in this document is accurate and reliable. However, the information is subject to change without notice and is provided "AS IS" without warranty of any kind (express or implied). Customers are advised to obtain the latest version of relevant information to verify, before placing orders, that information being relied on is current and complete. All products are sold subject to the terms and conditions of sale supplied at the time of order acknowledgment, including those pertaining to warranty, indemnification, and limitation of liability. No responsibility is assumed by Cirrus for the use of this information, including use of this information as the basis for manufacture or sale of any items, or for infringement of patents or other rights of third parties. This document is the property of Cirrus and by furnishing this information, Cirrus grants no license, express or implied under any patents, mask work rights, copyrights, trademarks, trade secrets or other intellectual property rights. Cirrus owns the copyrights associated with the information contained herein and gives consent for copies to be made of the information only for use within your organization with respect to Cirrus integrated circuits or other products of Cirrus. This consent does not extend to other copying such as copying for general distribution, advertising or promotional purposes, or for creating any work for resale.

CERTAIN APPLICATIONS USING SEMICONDUCTOR PRODUCTS MAY INVOLVE POTENTIAL RISKS OF DEATH, PERSONAL INJURY, OR SEVERE PROPERTY OR ENVIRONMENTAL DAMAGE ("CRITICAL APPLICATIONS"). CIRRUS PRODUCTS ARE NOT DESIGNED, AUTHORIZED OR WARRANTED TO BE SUITABLE FOR USE IN PRODUCTS SURGICALLY IMPLANTED INTO THE BODY, AUTOMOTIVE SAFETY OR SECURITY DEVICES, LIFE SUPPORT PRODUCTS OR OTHER CRITICAL APPLICATIONS. INCLUSION OF CIRRUS PRODUCTS IN SUCH APPLICATIONS IS UNDERSTOOD TO BE FULLY AT THE CUSTOMER'S RISK AND CIRRUS DISCLAIMS AND MAKES NO WARRANTY, EXPRESS, STATUTORY OR IMPLIED, INCLUDING THE IMPLIED WARRANTIES OF MERCHANTABILITY AND FITNESS FOR PARTICULAR PURPOSE, WITH REGARD TO ANY CIRRUS PRODUCT THAT IS USED IN SUCH A MANNER. IF THE CUSTOMER OR CUSTOMER'S CUSTOMER USES OR PERMITS THE USE OF CIRRUS PRODUCTS IN CRITICAL APPLICATIONS, CUSTOMER AGREES, BY SUCH USE, TO FULLY INDEMNIFY CIRRUS, ITS OFFICERS, DIRECTORS, EMPLOYEES, DISTRIBUTORS AND OTHER AGENTS FROM ANY AND ALL LIABILITY, INCLUDING ATTORNEYS' FEES AND COSTS, THAT MAY RESULT FROM OR ARISE IN CONNECTION WITH THESE USES.

Cirrus Logic, Cirrus, and the Cirrus Logic logo designs, Apex and Apex Precision Power are trademarks of Cirrus Logic, Inc. All other brand and product names in this document may be trademarks or service marks of their respective owners.